

CSc I6716
Fall 2010

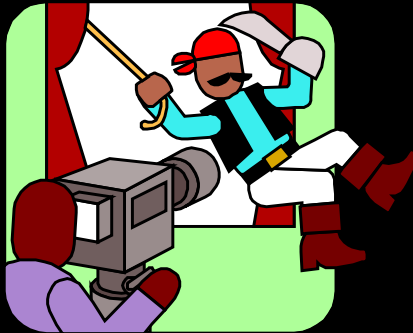

Topic 1 of Part I
Image Formation

The slides in this lecture were kindly provided by

Professor Allen Hanson

University of Massachusetts at Amherst

- Image Formation Basic Steps
- Geometry
 - Pinhole camera model & Thin lens model
 - Perspective projection & Fundamental equation
- Radiometry
- Photometry
 - Color, human vision, & digital imaging
- Digitalization
 - Sampling, quantization & tessellations
- More on Digital Images
 - Neighbors, connectedness & distances

- 
- Image Formation Basic Steps
 - Geometry
 - Pinhole camera model & Thin lens model
 - Perspective projection & Fundamental equation
 - Radiometry
 - Photometry
 - Color, human vision, & digital imaging
 - Digitalization
 - Sampling, quantization & tessellations
 - More on Digital Images
 - Neighbors, connectedness & distances

- An image can be represented by an image function whose general form is $f(\mathbf{x},\mathbf{y})$.
- $f(\mathbf{x},\mathbf{y})$ is a vector-valued function whose arguments represent a pixel location.
- The value of $f(\mathbf{x},\mathbf{y})$ can have different interpretations in different kinds of images.

Examples

Intensity Image

- $f(\mathbf{x},\mathbf{y})$ = intensity of the scene

Range Image

- $f(\mathbf{x},\mathbf{y})$ = depth of the scene from imaging system

Color Image

- $f(\mathbf{x},\mathbf{y}) = \{f_r(\mathbf{x},\mathbf{y}), f_g(\mathbf{x},\mathbf{y}), f_b(\mathbf{x},\mathbf{y})\}$

Video

- $f(\mathbf{x},\mathbf{y},t)$ = temporal image sequence

- Radiometry is the part of image formation concerned with the relation among the amounts of light energy emitted from light sources, reflected from surfaces, and registered by sensors.

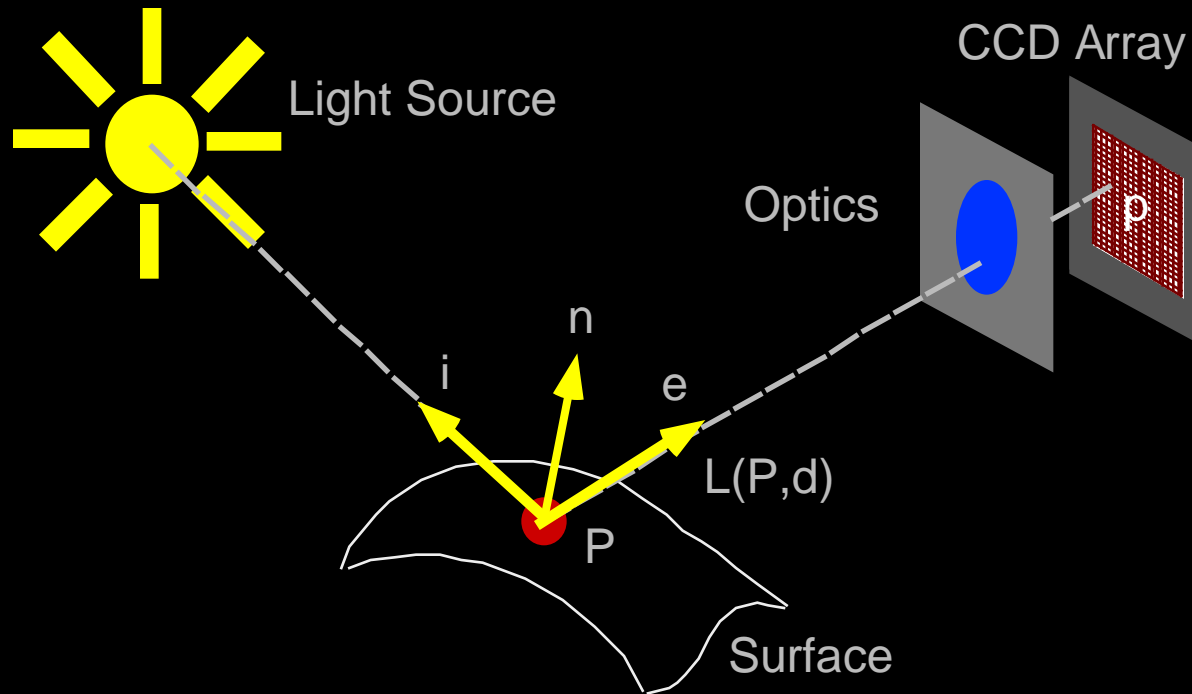

- The interaction between light and matter can take many forms:
 - Reflection
 - Refraction
 - Diffraction
 - Absorption
 - Scattering

- Typical imaging scenario:
 - visible light
 - ideal lenses
 - standard sensor (e.g. TV camera)
 - opaque objects
- Goal

To create 'digital' images which can be processed to recover some of the characteristics of the 3D world which was imaged.

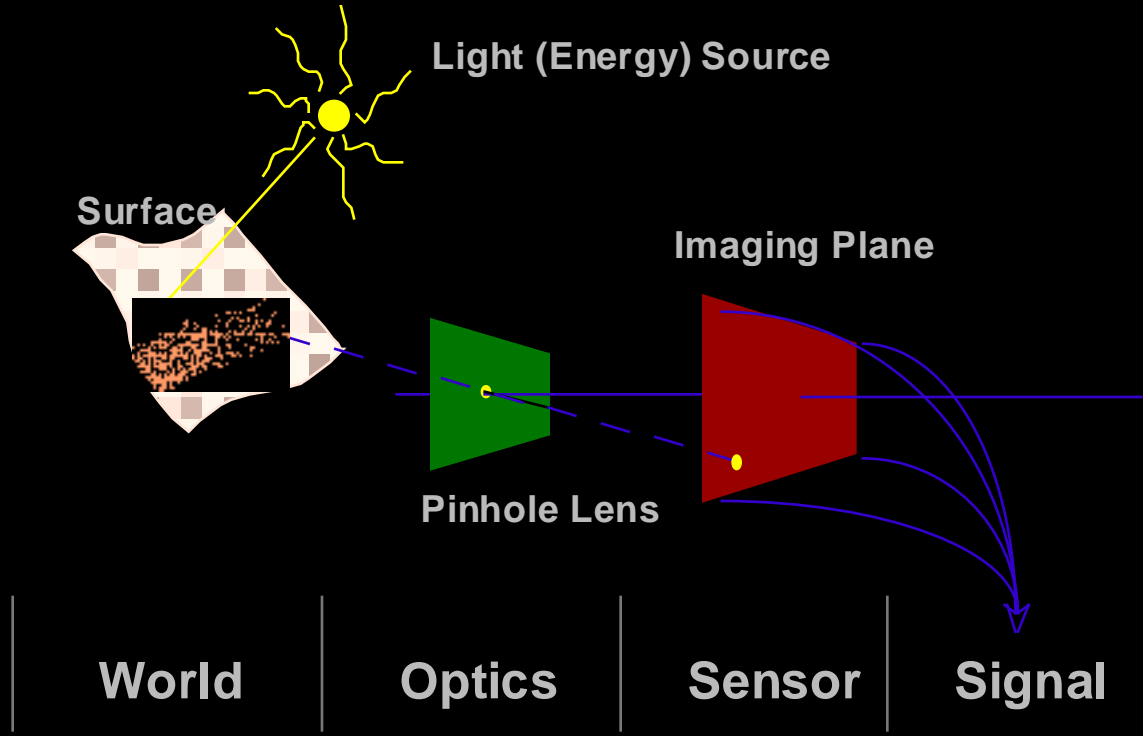

- | | |
|------------|--------------------------------------|
| B&W Film | Silver Density |
| Color Film | Silver density in three color layers |
| TV Camera | Electrical |

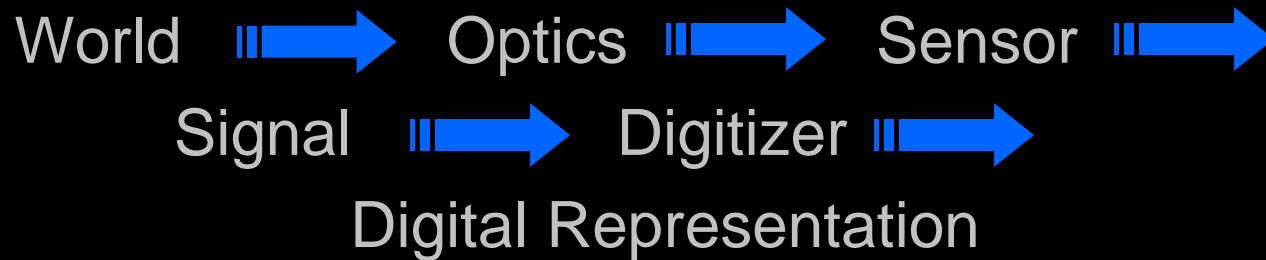

World	reality
Optics	focus {light} from world on sensor
Sensor	converts {light} to {electrical energy}
Signal	representation of incident light as continuous electrical energy
Digitizer	converts continuous signal to discrete signal
Digital Rep.	final representation of reality in computer memory

- Geometry
 - concerned with the relationship between points in the three-dimensional world and their images
- Radiometry
 - concerned with the relationship between the amount of light radiating from a surface and the amount incident at its image
- Photometry
 - concerned with ways of measuring the intensity of light
- Digitization
 - concerned with ways of converting continuous signals (in both space and time) to digital approximations

- 
- Image Formation Basic Steps
 - Geometry
 - Pinhole camera model & Thin lens model
 - Perspective projection & Fundamental equation
 - Radiometry
 - Photometry
 - Color, human vision, & digital imaging
 - Digitalization
 - Sampling, quantization & tessellations
 - More on Digital Images
 - Neighbors, connectedness & distances

- Geometry describes the projection of:

three-dimensional
(3D) world

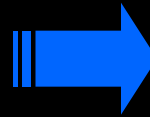

two-dimensional
(2D) image plane.

- Typical Assumptions

- Light travels in a straight line

- **Optical Axis:** the axis perpendicular to the image plane and passing through the pinhole (also called the central projection ray)

- Each point in the image corresponds to a particular direction defined by a **ray** from that point through the pinhole.

- Various kinds of projections:

- - perspective - oblique
- - orthographic - isometric
- - spherical

- Two models are commonly used:
 - Pin-hole camera
 - Optical system composed of lenses
- **Pin-hole** is the basis for most graphics and vision
 - Derived from physical construction of early cameras
 - Mathematics is very straightforward
- **Thin lens** model is first of the lens models
 - Mathematical model for a physical lens
 - Lens gathers light over area and focuses on image plane.

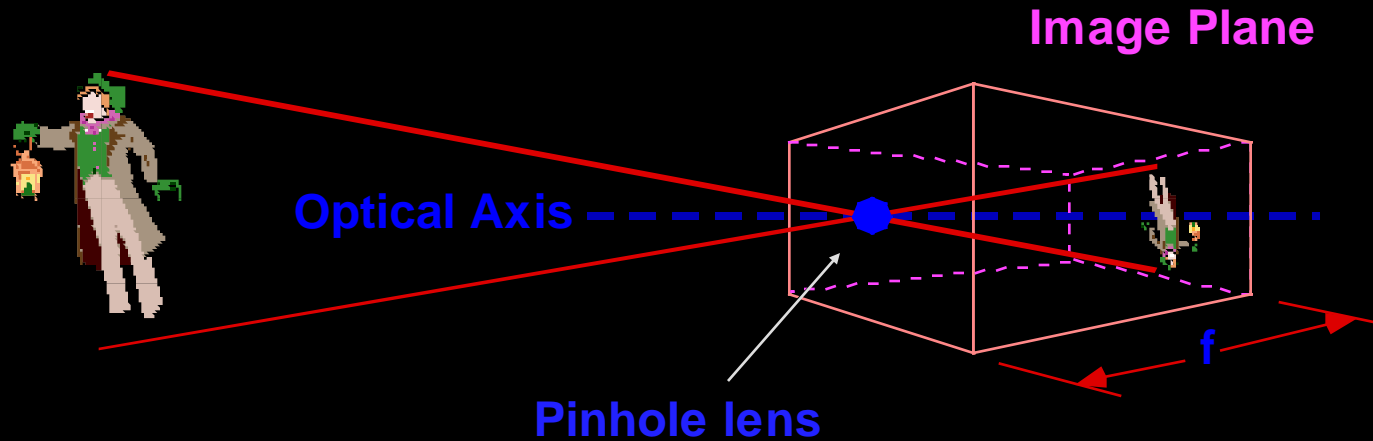

- World projected to 2D Image
 - Image inverted
 - Size reduced
 - Image is dim
 - No direct depth information
- f called the focal length of the lens
- Known as perspective projection

Amsterdam



Photo by Robert Kosara, robert@kosara.net

<http://www.kosara.net/gallery/pinholeamsterdam/pic01.html>

- Consider case with object on the optical axis:

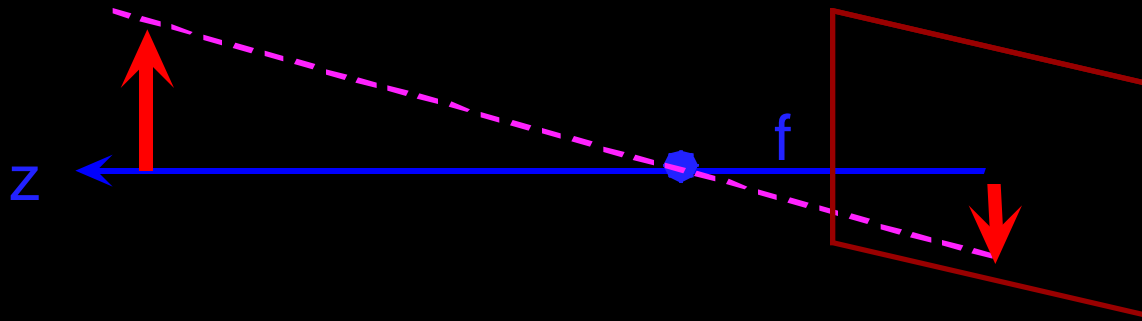

- More convenient with upright image:

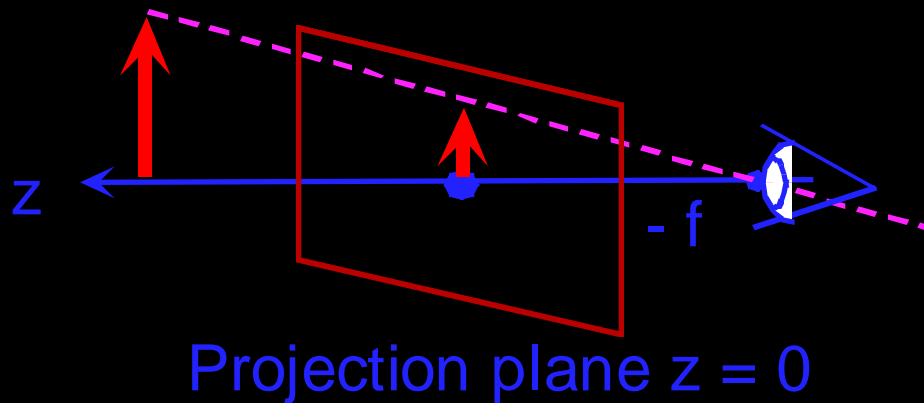

- Equivalent mathematically

- Rays entering parallel on one side converge at focal point.
- Rays diverging from the focal point become parallel.

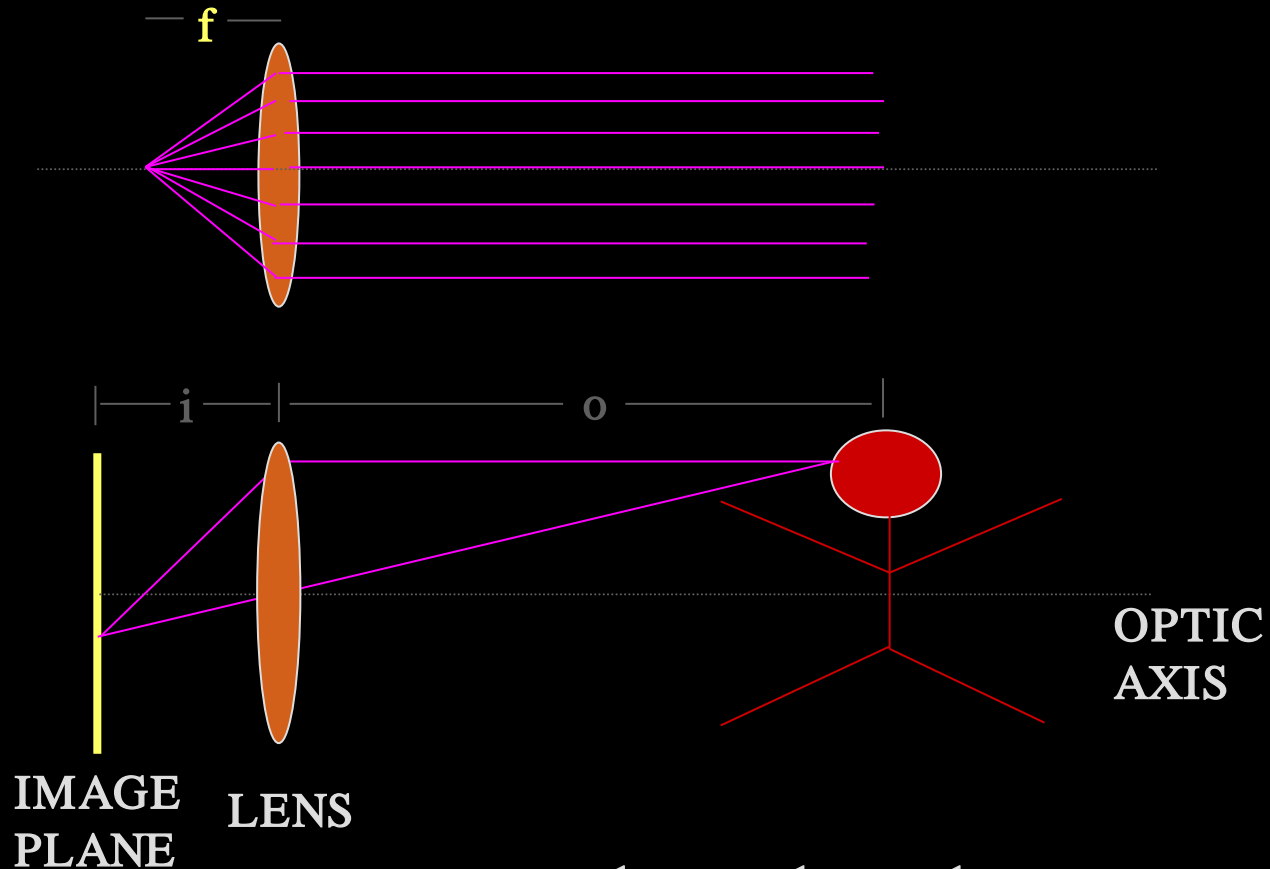

$$\frac{1}{f} = \frac{1}{i} + \frac{1}{o} \quad \text{'THIN LENS LAW'}$$

■ Simplified Case:

- Origin of world and image coordinate systems coincide
- Y-axis aligned with y -axis
- X-axis aligned with x -axis
- Z-axis along the central projection ray

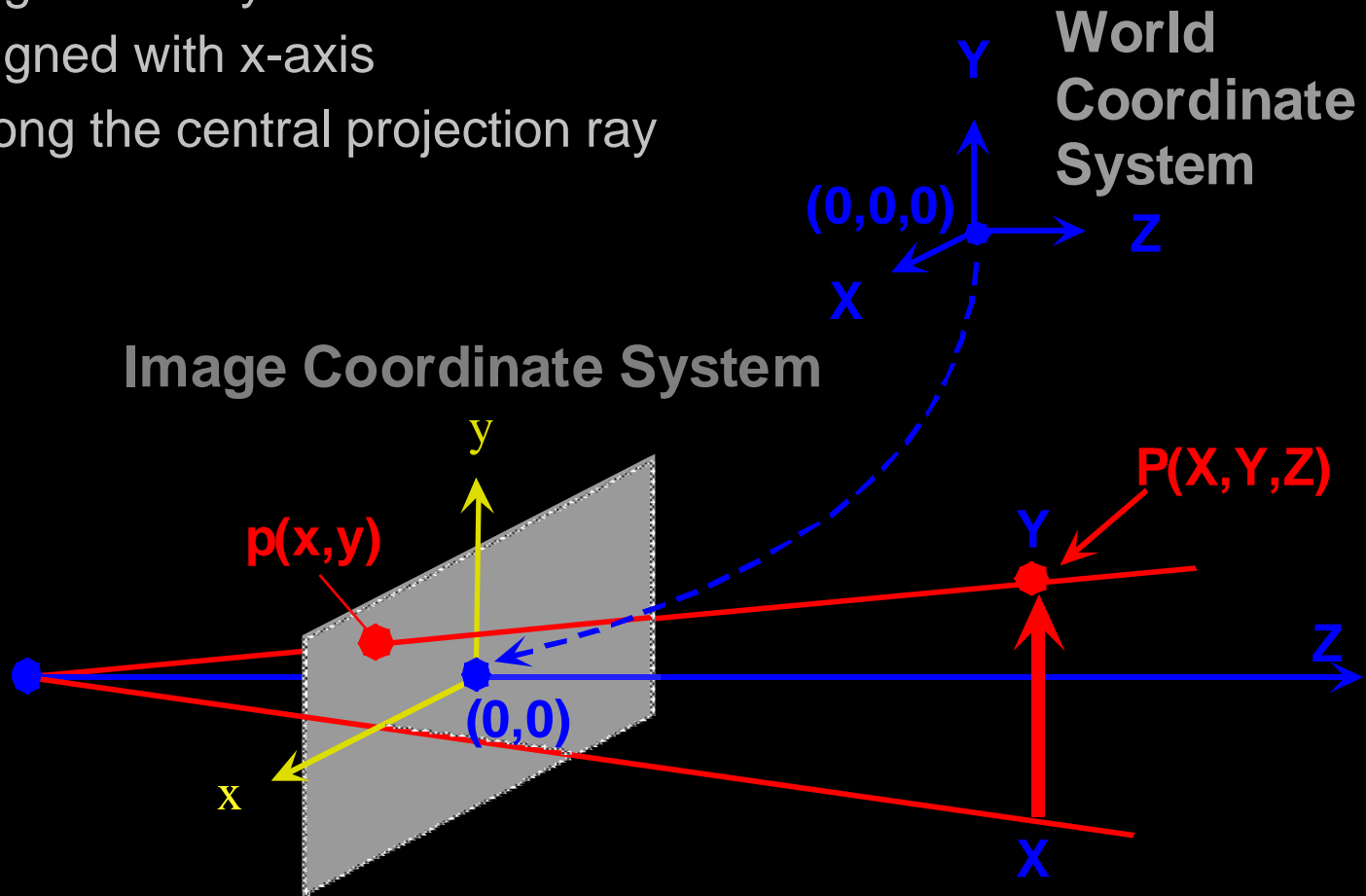

- Compute the image coordinates of p in terms of the world coordinates of P .

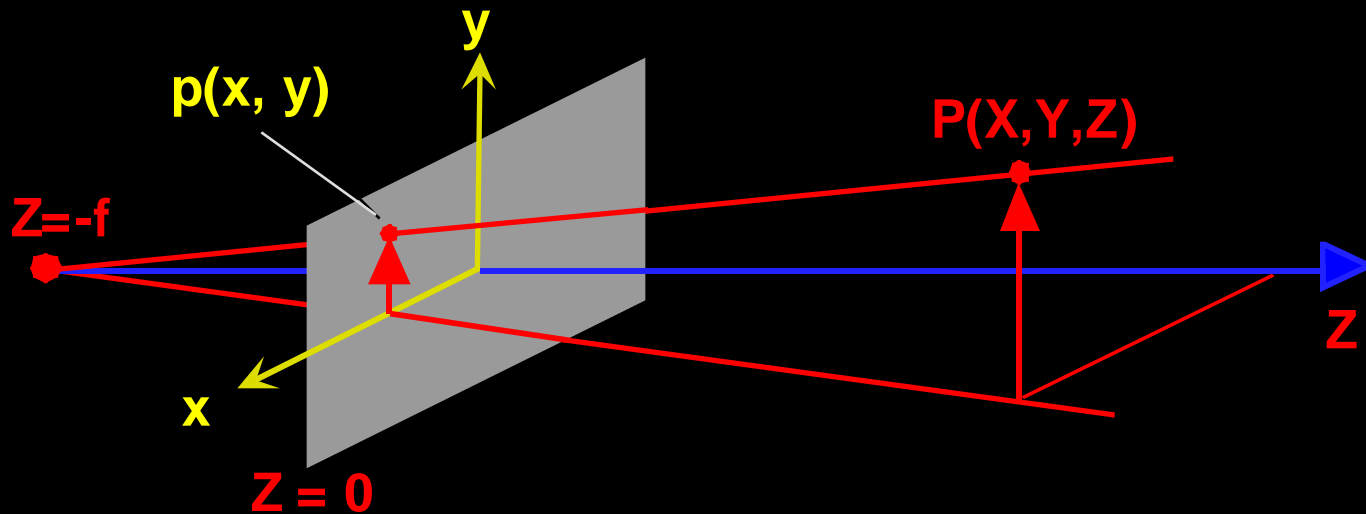

- Look at projections in x - z and y - z planes

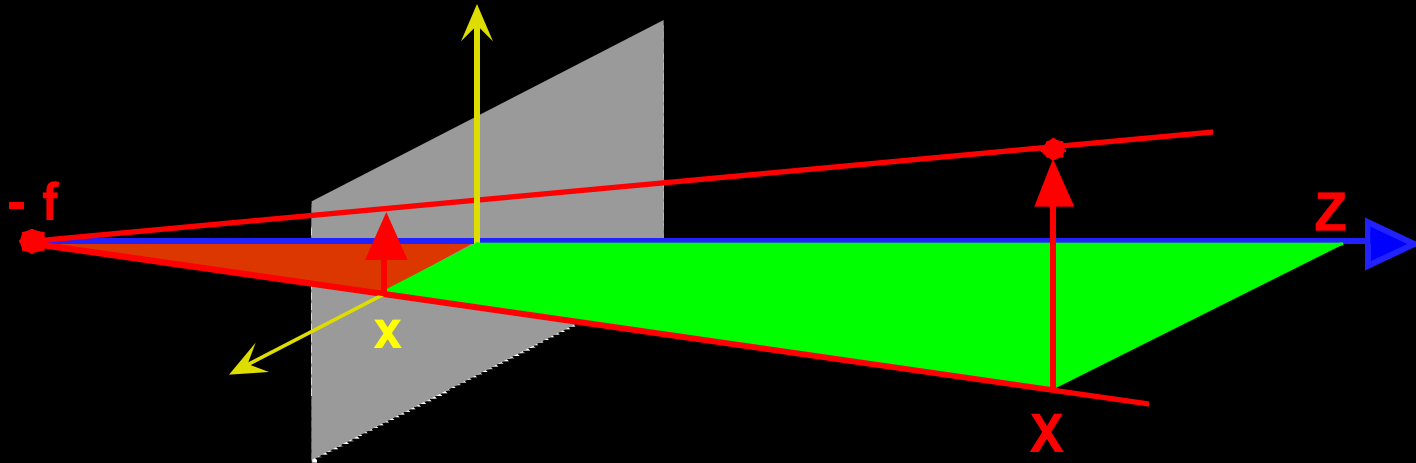

■ By similar triangles: $\frac{x}{f} = \frac{X}{Z+f}$

$$x = \frac{fX}{Z+f}$$

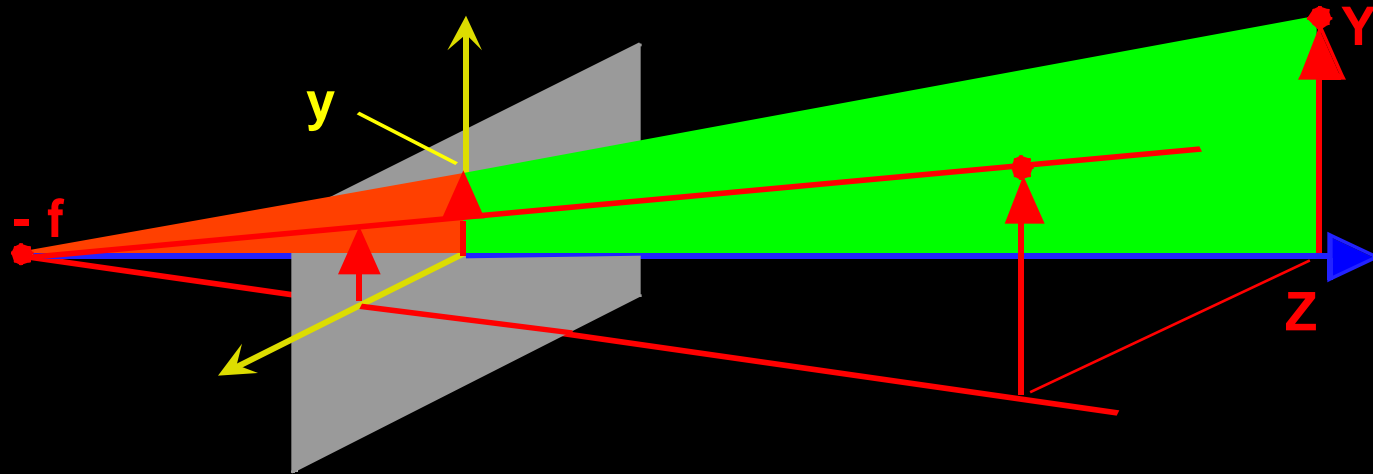

■ By similar triangles: $\frac{y}{f} = \frac{Y}{Z+f}$

$$y = \frac{fY}{Z+f}$$

- Given point $P(X, Y, Z)$ in the 3D world
- The two equations:

$$x = \frac{fX}{Z+f}$$

$$y = \frac{fY}{Z+f}$$

- transform world coordinates (X, Y, Z)
into image coordinates (x, y)
- Question:
 - What is the equation if we select the origin of both coordinate systems at the nodal point?

- Given a center of projection and image coordinates of a point, it is not possible to recover the 3D depth of the point from a single image.

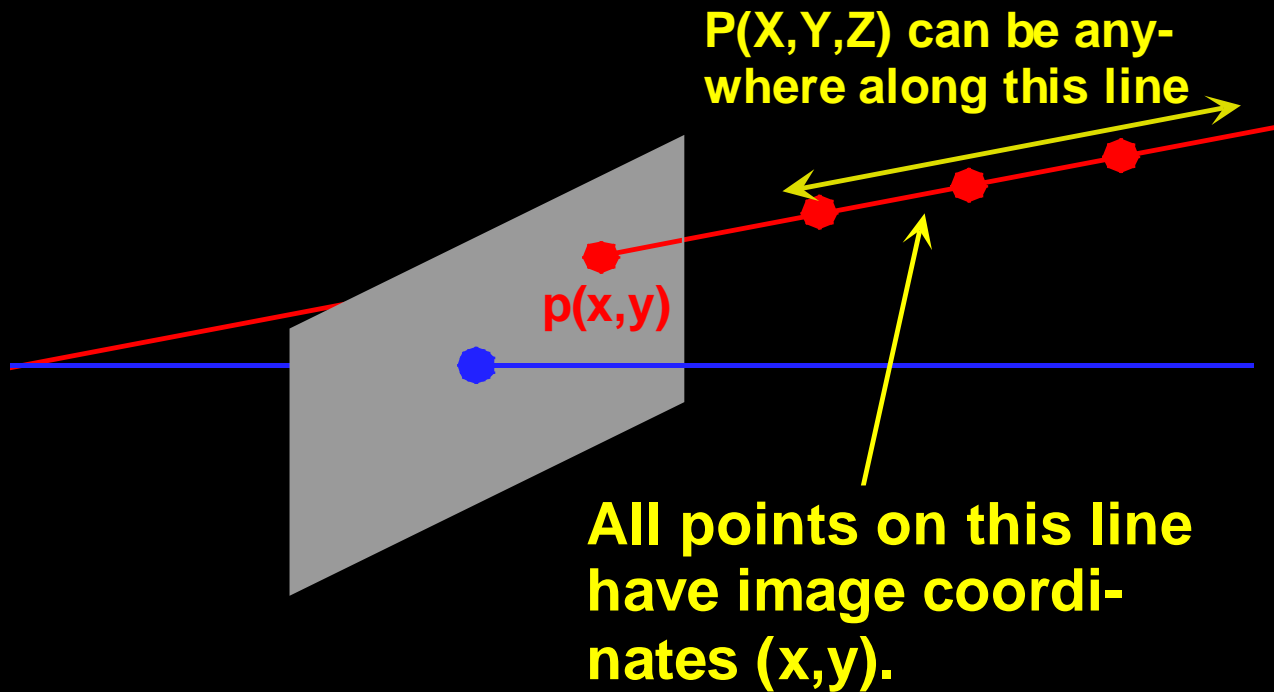

In general, at least two images of the same point taken from two different locations are required to recover depth.

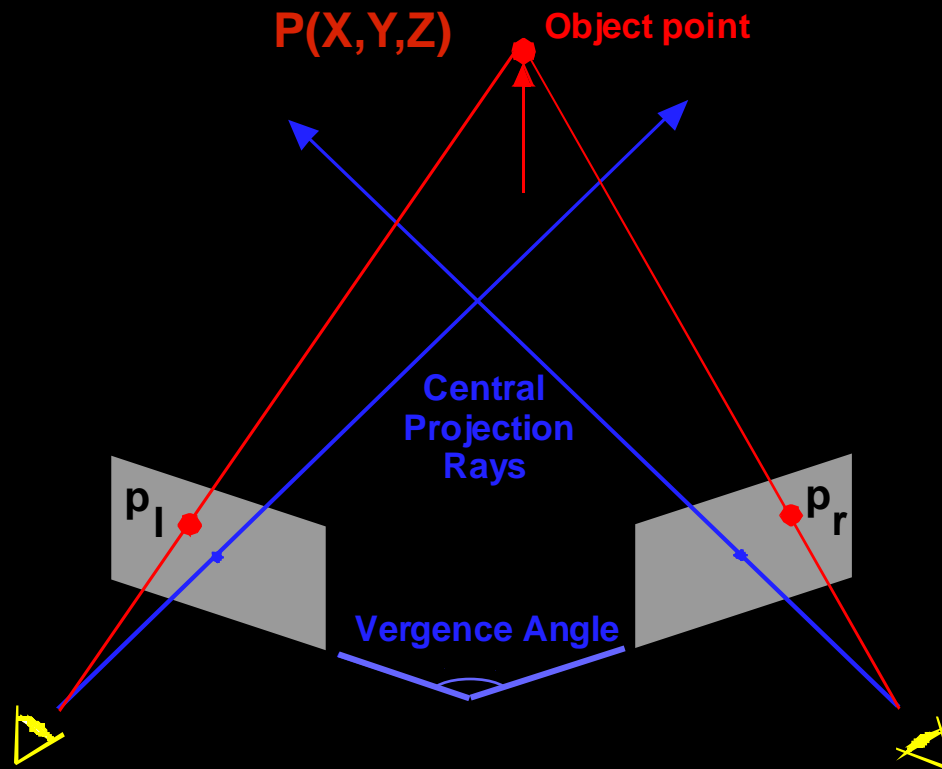

- Depth obtained by triangulation
- Correspondence problem: p_l and p_r must correspond to the left and right projections of P , respectively.

- Image Formation Basic Steps
- Geometry
 - Pinhole camera model & Thin lens model
 - Perspective projection & Fundamental equation
- ■ Radiometry
- Photometry
 - Color, human vision, & digital imaging
- Digitalization
 - Sampling, quantization & tessellations
- More on Digital Images
 - Neighbors, connectedness & distances

- **Image**: two-dimensional array of 'brightness' values.
- **Geometry**: where in an image a point will project.
- **Radiometry**: what the brightness of the point will be.
 - **Brightness**: informal notion used to describe both scene and image brightness.
 - **Image brightness**: related to energy flux incident on the image plane: => **IRRADIANCE**
 - **Scene brightness**: brightness related to energy flux emitted (radiated) from a surface: => **RADIANCE**

- Goal: Relate the radiance of a surface to the irradiance in the image plane of a simple optical system.

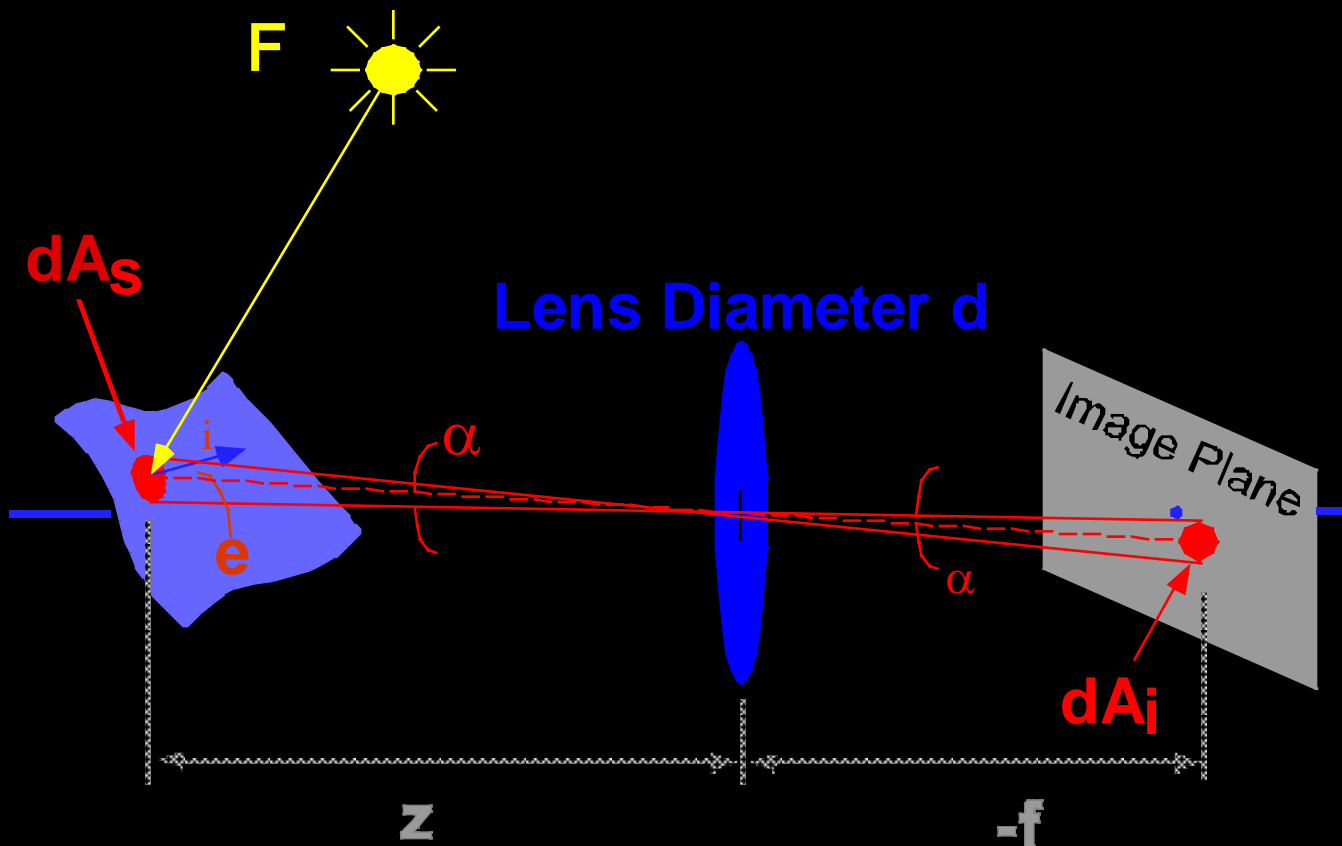

$$E_i = L_s \frac{\pi}{4} \left[\frac{d}{-f} \right]^2 \cos^4 \alpha$$

- Image irradiance is proportional to:
 - Scene radiance L_s
 - Focal length of lens f
 - Diameter of lens d
 - f/d is often called the **f-number** of the lens
 - Off-axis angle α

Lens Center

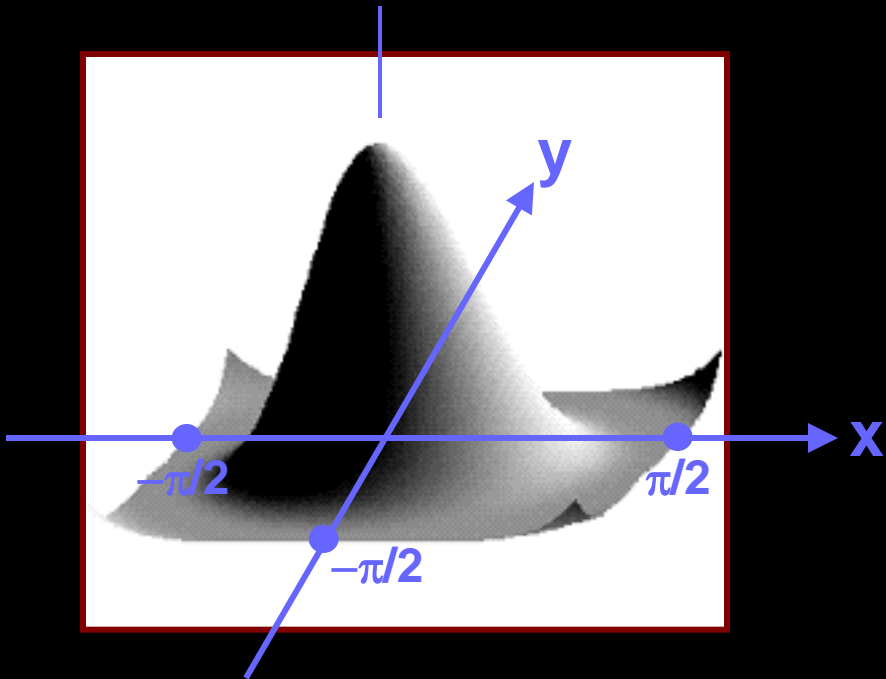

Top view shaded by height

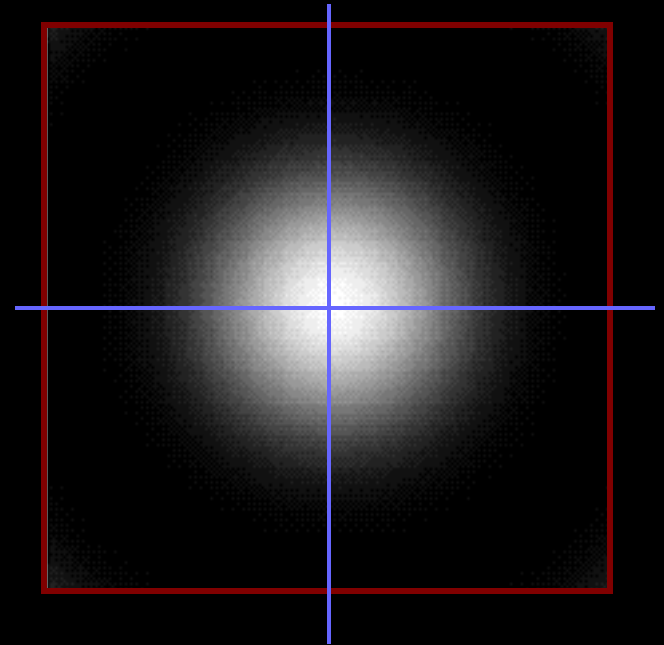

- Image Formation Basic Steps
- Geometry
 - Pinhole camera model & Thin lens model
 - Perspective projection & Fundamental equation
- Radiometry
- Photometry
 - Color, human vision, & digital imaging
- Digitalization
 - Sampling, quantization & tessellations
- More on Digital Images
 - Neighbors, connectedness & distances

- Photometry:
Concerned with mechanisms for converting light energy into electrical energy.



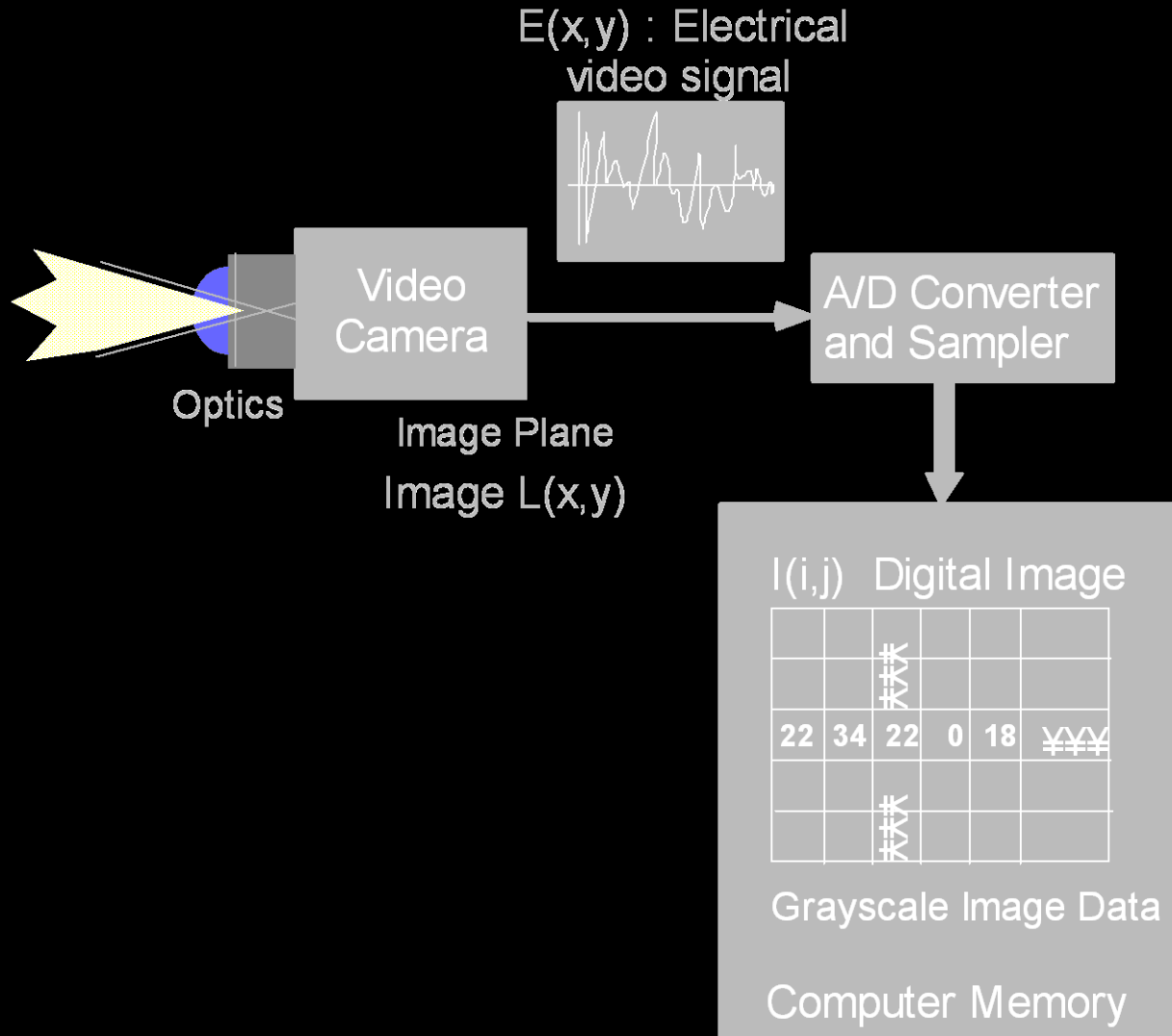

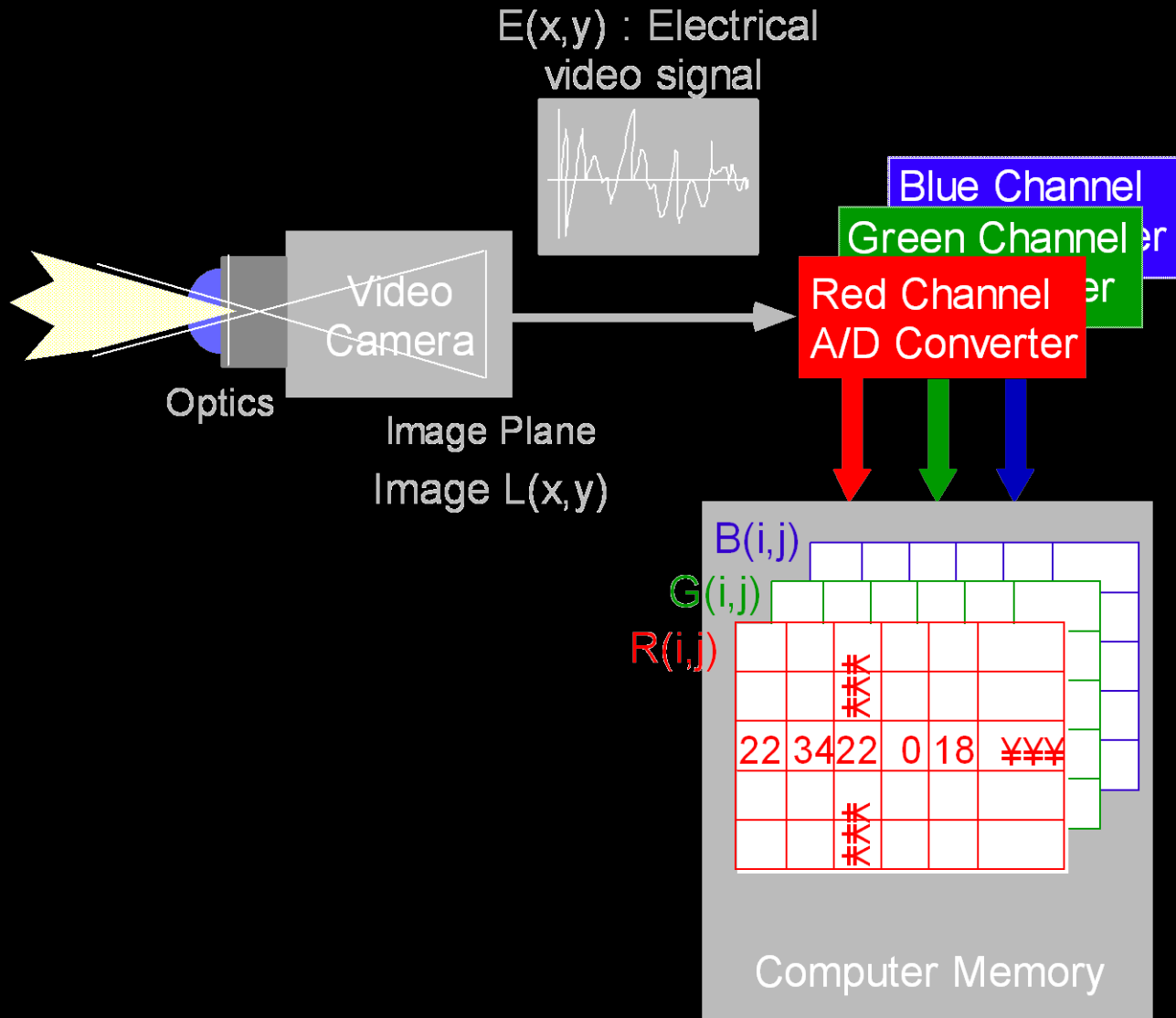

Color Cube and Color Wheel

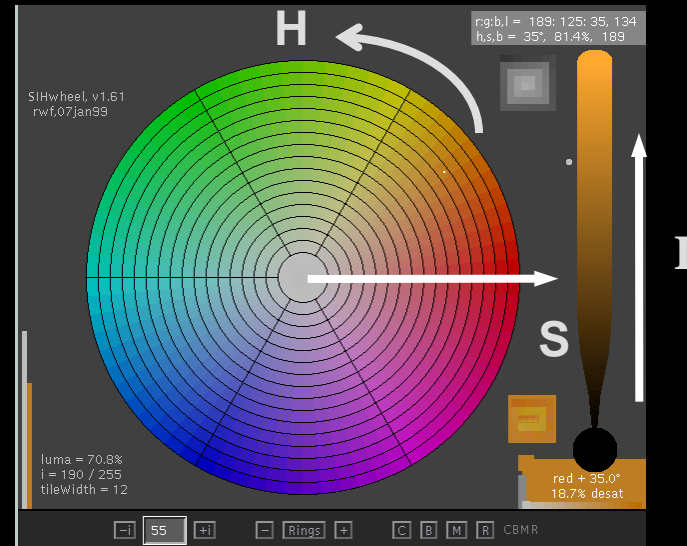
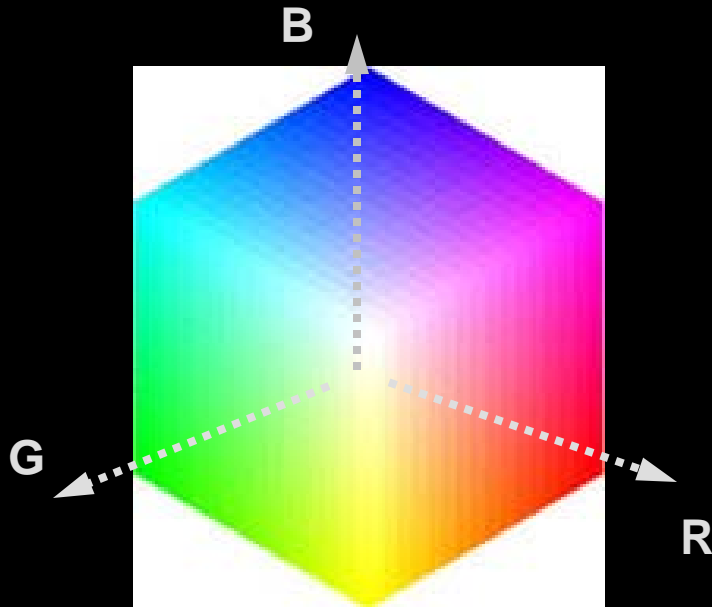

For color spaces, please read

- Color Cube <http://www.morecrayons.com/palettes/webSmart/>
- Color Wheel <http://r0k.us/graphics/SIHwheel.html>
- http://www-viz.tamu.edu/faculty/parke/ends489f00/notes/sec1_4.html

- Three CCD-chips cameras
 - R, G, B separately, AND digital signals instead analog video
- One CCD Cameras
 - Bayer color filter array
 - <http://www.siliconimaging.com/RGB%20Bayer.htm>

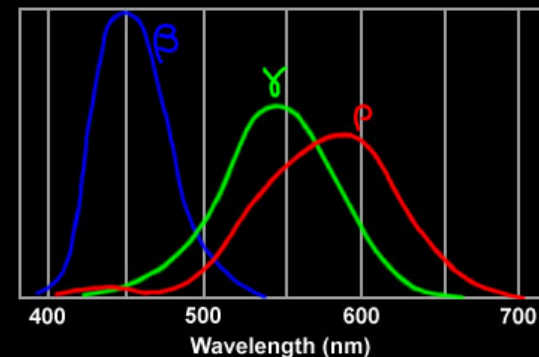
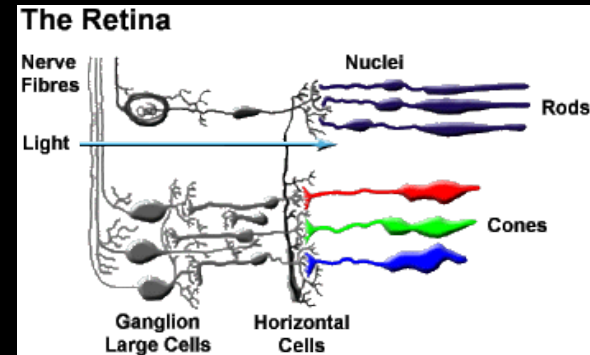
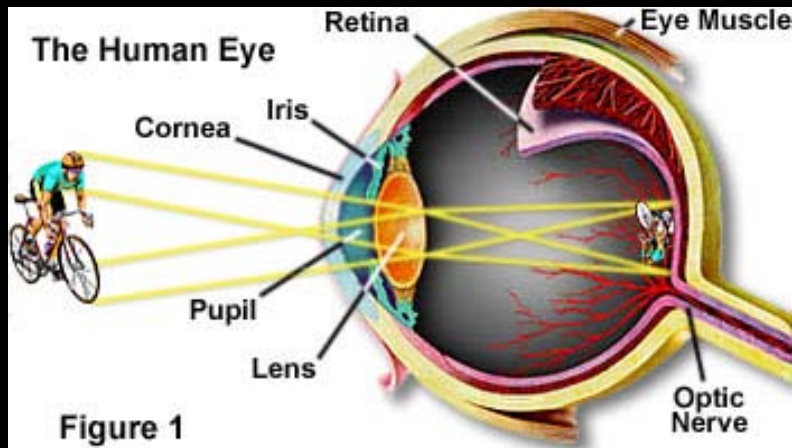

- Visit a cool site with Interactive Java tutorial:
 - [Human Vision and Color Perception](#)
- Another site about human color perception:
 - [Color Vision](#)

- Image Formation Basic Steps
- Geometry
 - Pinhole camera model & Thin lens model
 - Perspective projection & Fundamental equation
- Radiometry
- Photometry
 - Color, human vision, & digital imaging
- Digitalization
 - Sampling, quantization & tessellations
- More on Digital Images
 - Neighbors, connectedness & distances



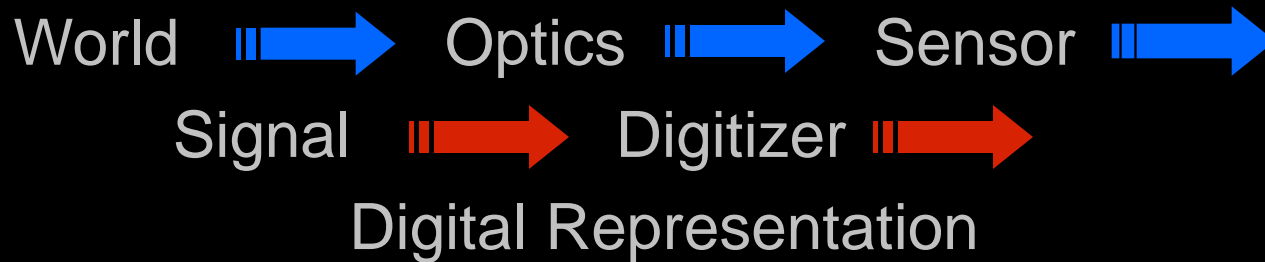

- Digitization: conversion of the continuous (in space and value) electrical signal into a digital signal (digital image)
- Three decisions must be made:
 - Spatial resolution (how many samples to take)
 - Signal resolution (dynamic range of values- quantization)
 - Tessellation pattern (how to 'cover' the image with sample points)

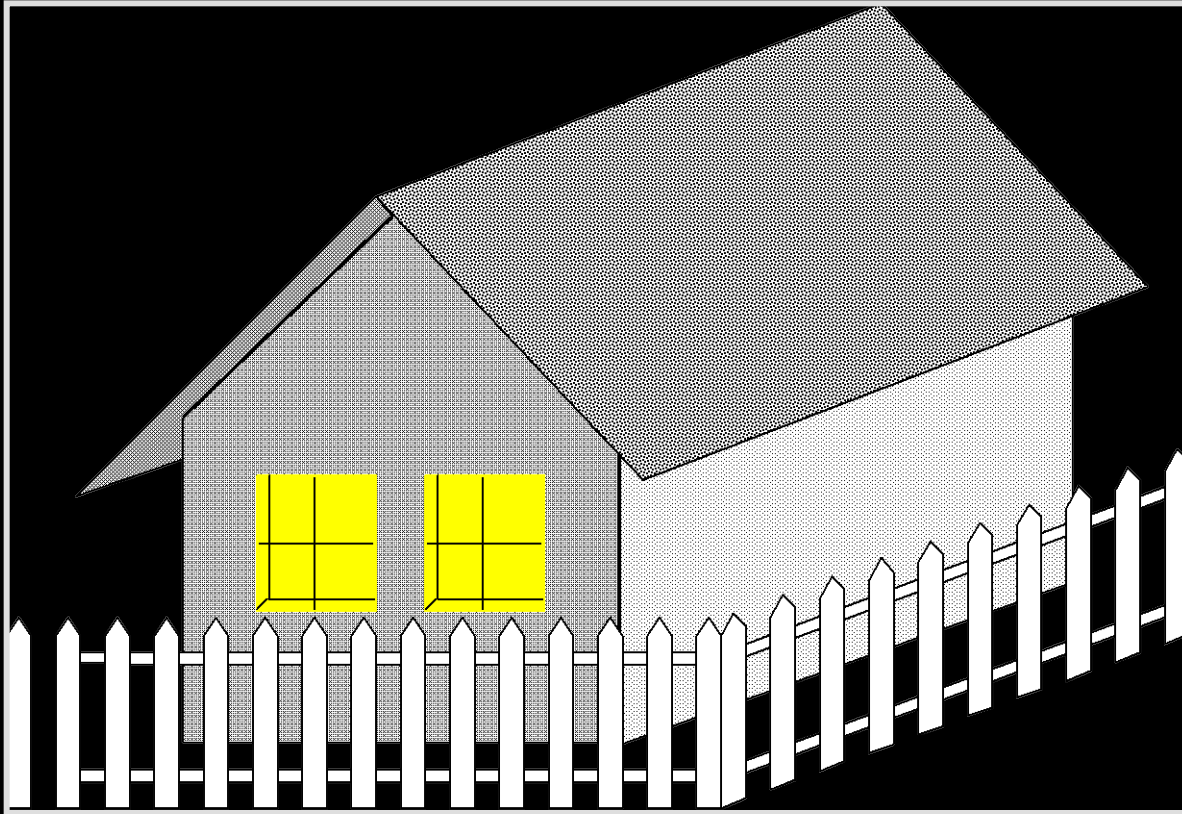

- Let's digitize this image
 - Assume a square sampling pattern
 - Vary density of sampling grid

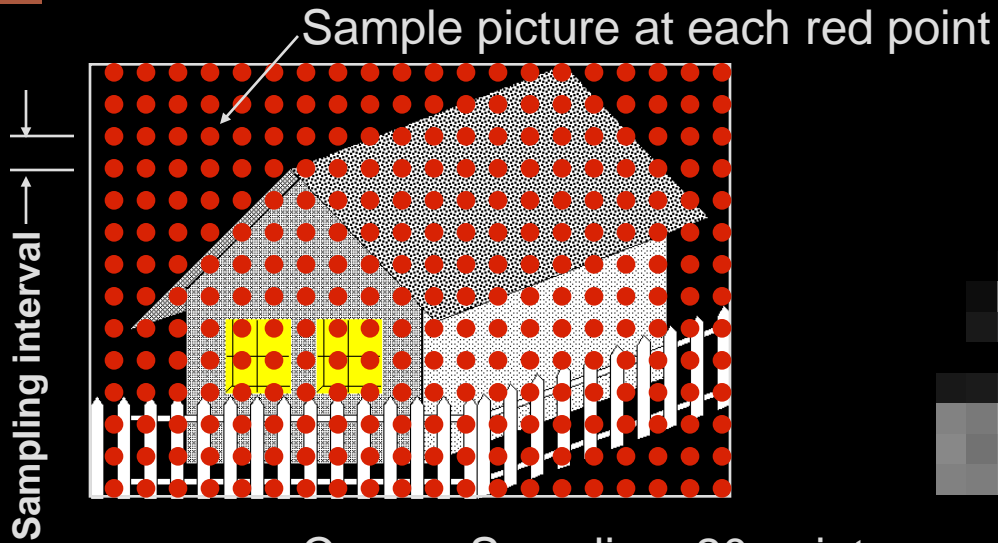

Coarse Sampling: 20 points per row by 14 rows

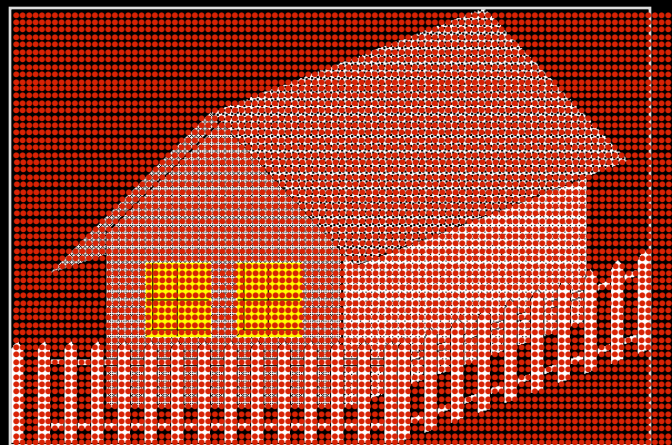

Finer Sampling: 100 points per row by 68 rows

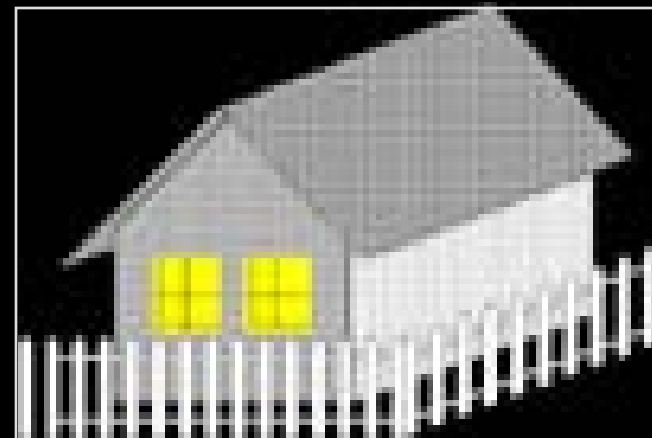

- Look in vicinity of the picket fence:

Sampling Interval: 

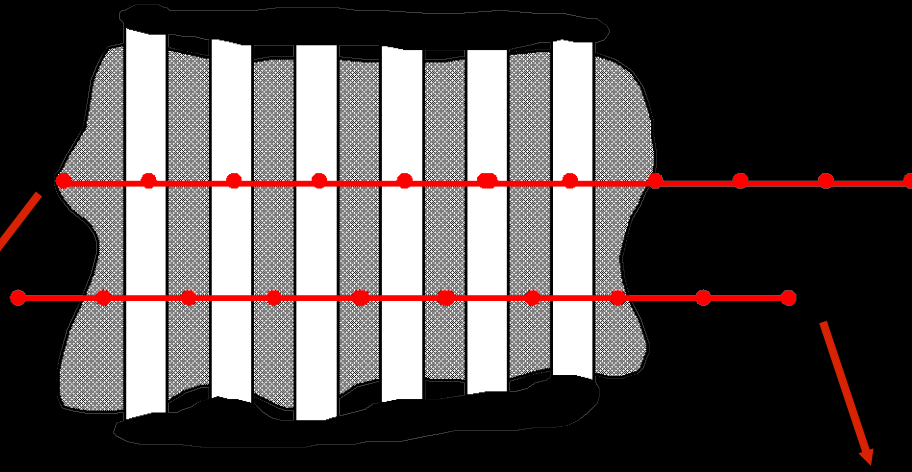

100	100	100	100	100	100
100	100	100	100	100	100
100	100	100	100	100	100
100	100	100	100	100	100

White Image!

**NO EVIDENCE
OF THE FENCE!**

40	40	40	40	40	40
40	40	40	40	40	40
40	40	40	40	40	40
40	40	40	40	40	40

Dark Gray Image!

- Look in vicinity of picket fence:

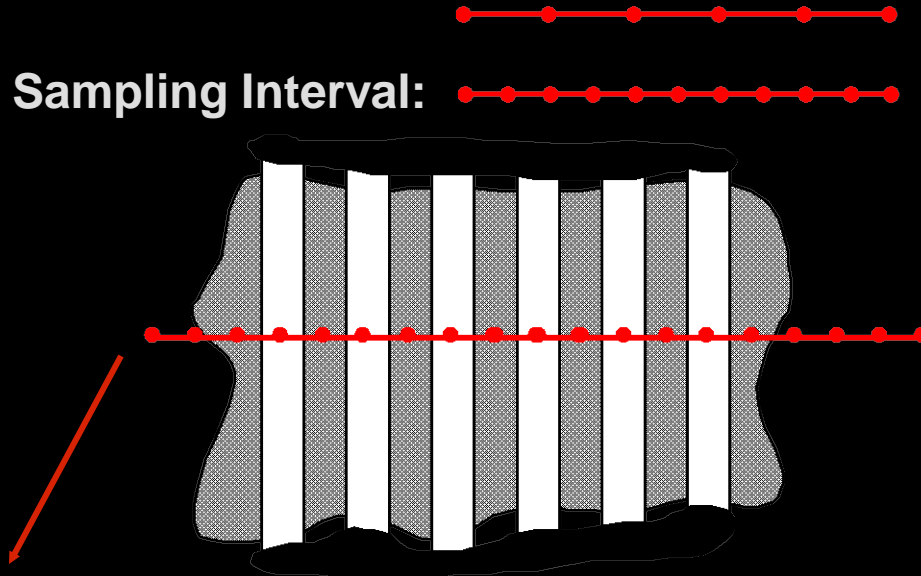

40	100	40	100	40
40	100	40	100	40
40	100	40	100	40
40	100	40	100	40

What's the difference between this attempt and the last one?

Now we've got a fence!

- Consider the repetitive structure of the fence:

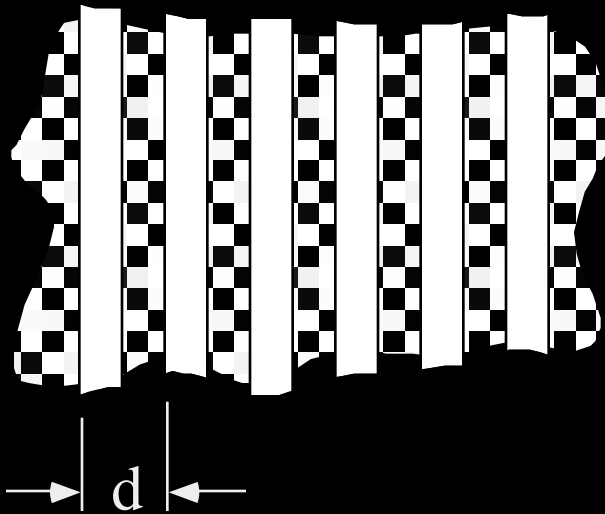

Sampling Intervals

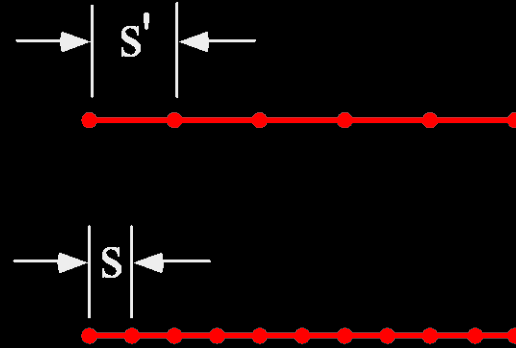

Case 1: $s' = d$

The sampling interval is equal to the size of the repetitive structure

NO FENCE

Case 2: $s = d/2$

The sampling interval is one-half the size of the repetitive structure

FENCE

- IF: the size of the smallest structure to be preserved is d
- THEN: the sampling interval must be smaller than $d/2$

- Can be shown to be true mathematically
- Repetitive structure has a certain frequency
 - To preserve structure must sample at twice the frequency
 - Holds for images, audio CDs, digital television....
- Leads naturally to Fourier Analysis (optional)

■ Rough Idea: Ideal Case

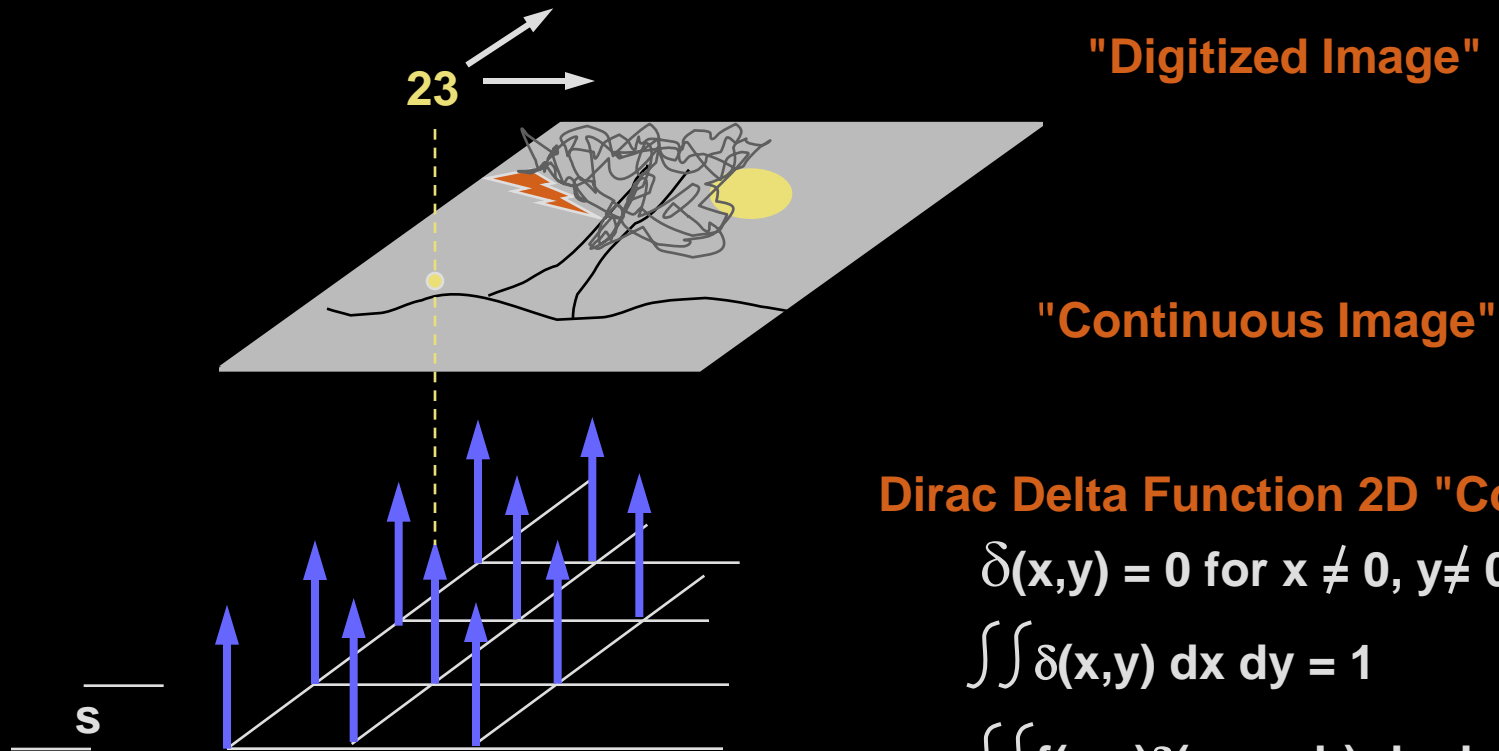

"Digitized Image"

"Continuous Image"

Dirac Delta Function 2D "Comb"

$$\delta(x,y) = 0 \text{ for } x \neq 0, y \neq 0$$

$$\iint \delta(x,y) dx dy = 1$$

$$\iint f(x,y)\delta(x-a,y-b) dx dy = f(a,b)$$

$$\delta(x-ns,y-ns) \text{ for } n = 1 \dots 32 \text{ (e.g.)}$$

■ Rough Idea: Actual Case

- Can't realize an ideal point function in real equipment
- "Delta function" equivalent has an area
- Value returned is the average over this area

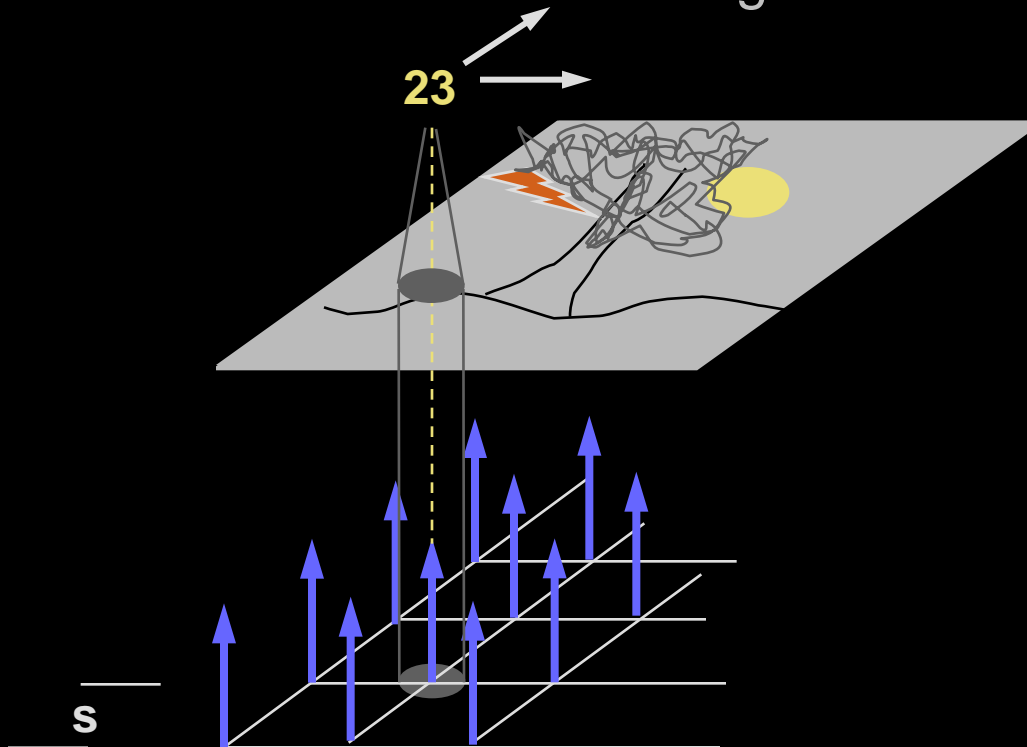



- Goal: determine a mapping from a continuous signal (e.g. analog video signal) to one of K discrete (digital) levels.

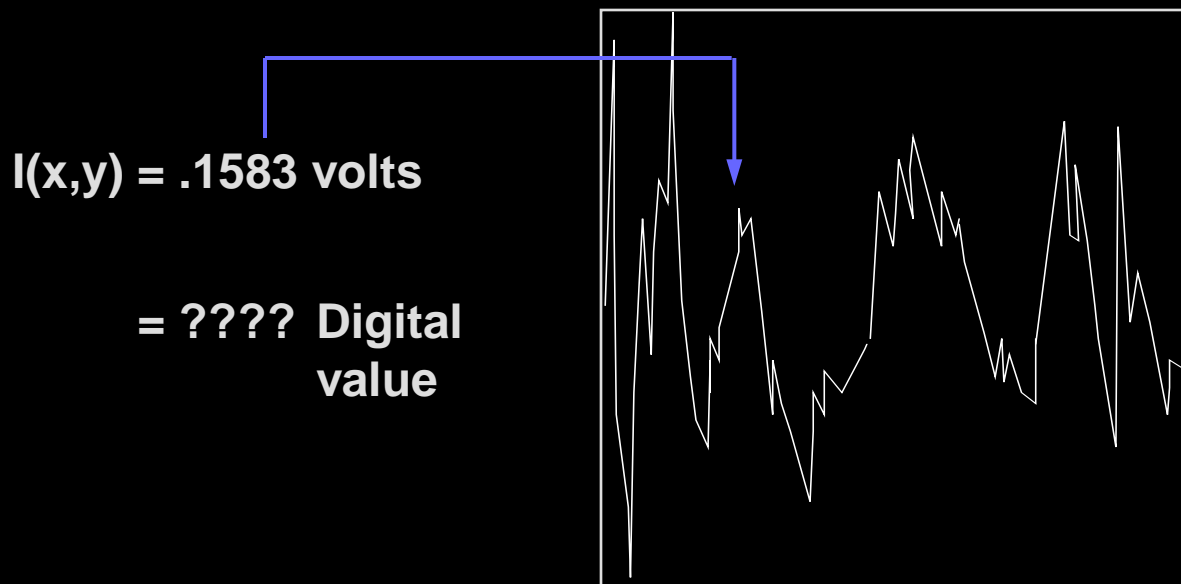

- $I(x,y)$ = continuous signal: $0 \cdot I \cdot M$
- Want to quantize to K values $0, 1, \dots, K-1$
- K usually chosen to be a power of 2:

K	#Levels	#Bits
2	2	1
4	4	2
8	8	3
16	16	4
32	32	5
64	64	6
128	128	7
256	256	8

- Mapping from input signal to output signal is to be determined.
- Several types of mappings: uniform, logarithmic, etc.

Original



Linear Ramp

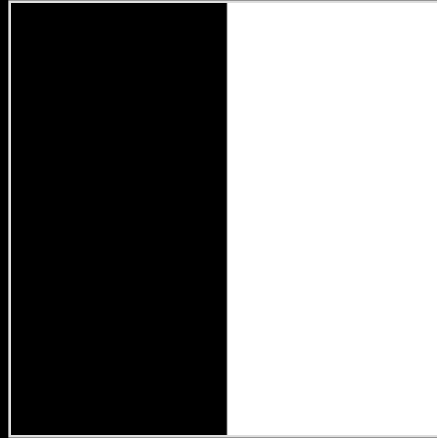

K=2

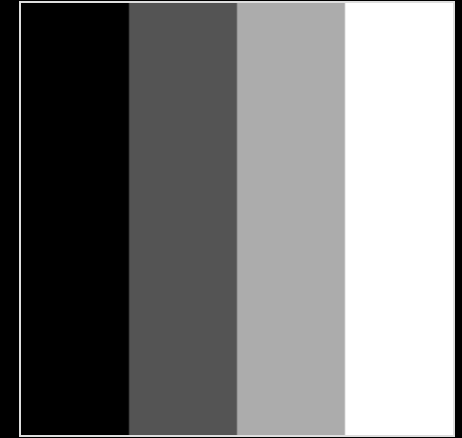

K=4

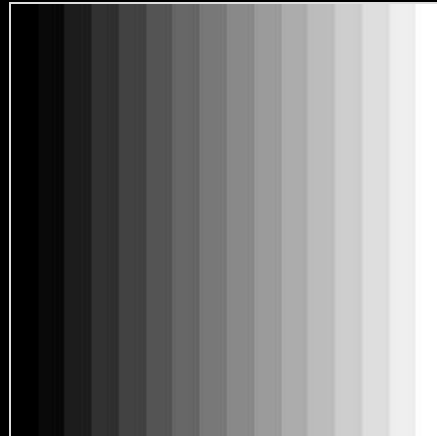

K=16

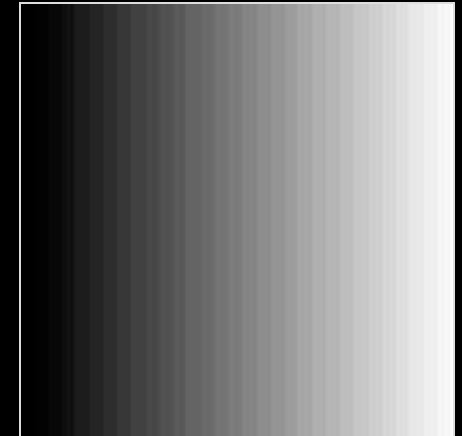

K=32



K=2 (each color)



K=4 (each color)

- Uniform quantization divides the signal range $[0-M]$ into K equal-sized intervals.
- The integers $0, \dots, K-1$ are assigned to these intervals.
- All signal values within an interval are represented by the associated integer value.
- Defines a mapping:

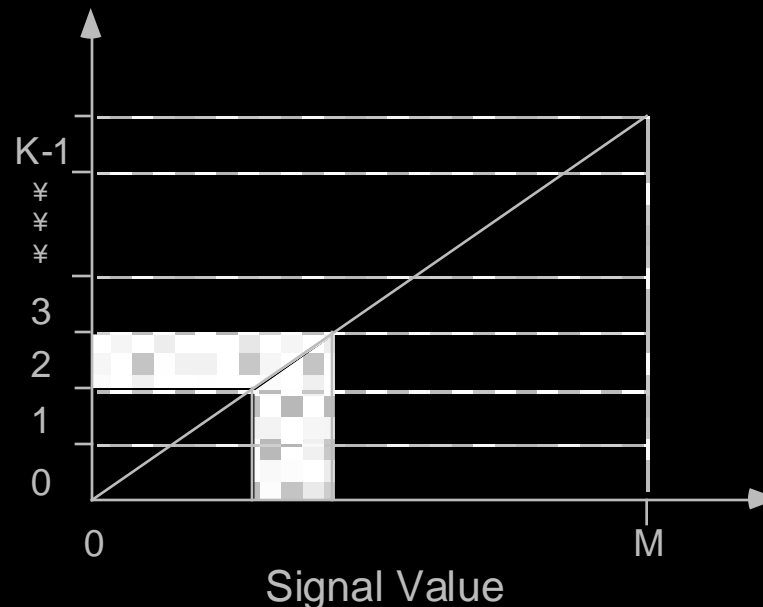

- Signal is $\log I(x,y)$.
- Effect is:

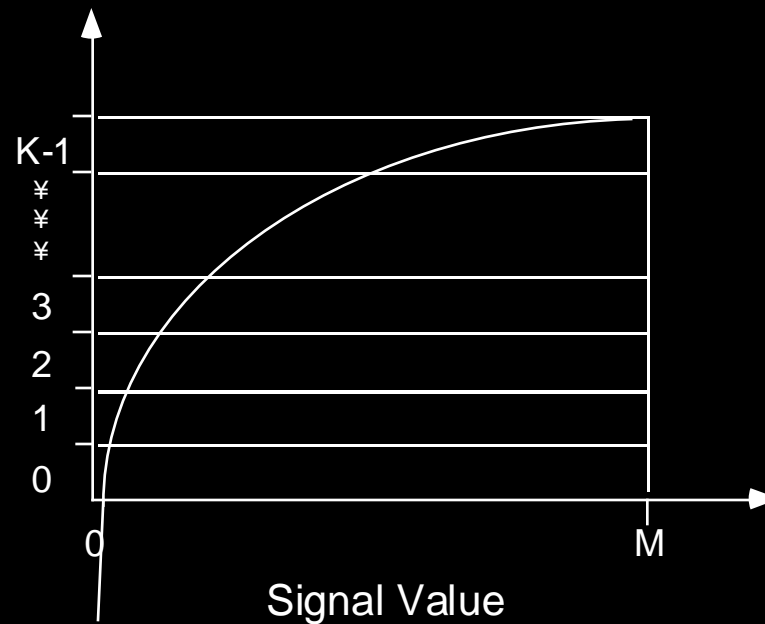

- Detail enhanced in the low signal values at expense of detail in high signal values.

Quantization Curve

Original

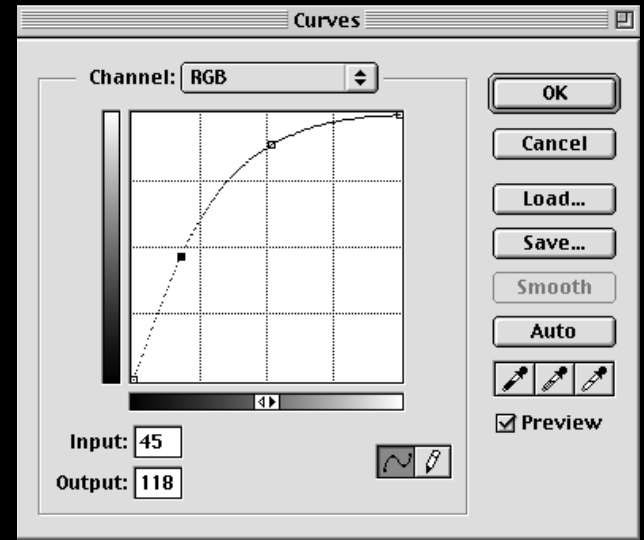

Logarithmic Quantization



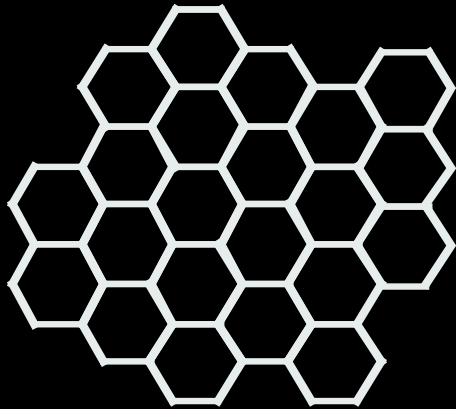

Hexagonal

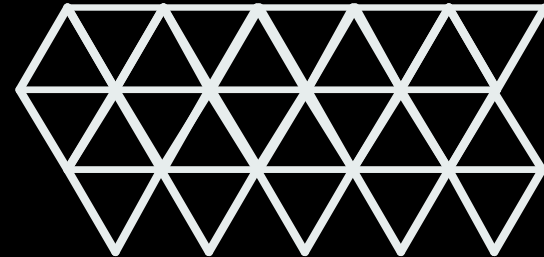

Triangular

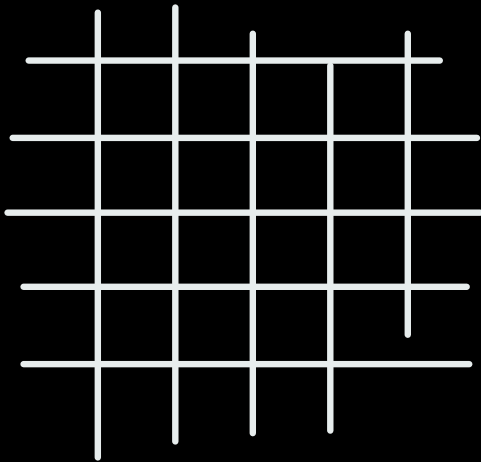

Rectangular

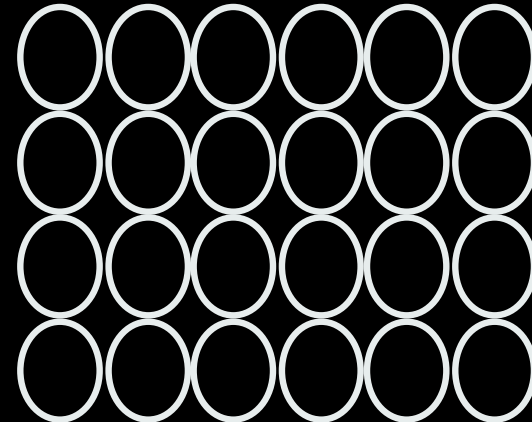

Typical

- Image Formation Basic Steps
- Geometry
 - Pinhole camera model & Thin lens model
 - Perspective projection & Fundamental equation
- Radiometry
- Photometry
 - Color, human vision, & digital imaging
- Digitalization
 - Sampling, quantization & tessellations
- More on Digital Images
 - Neighbors, connectedness & distances



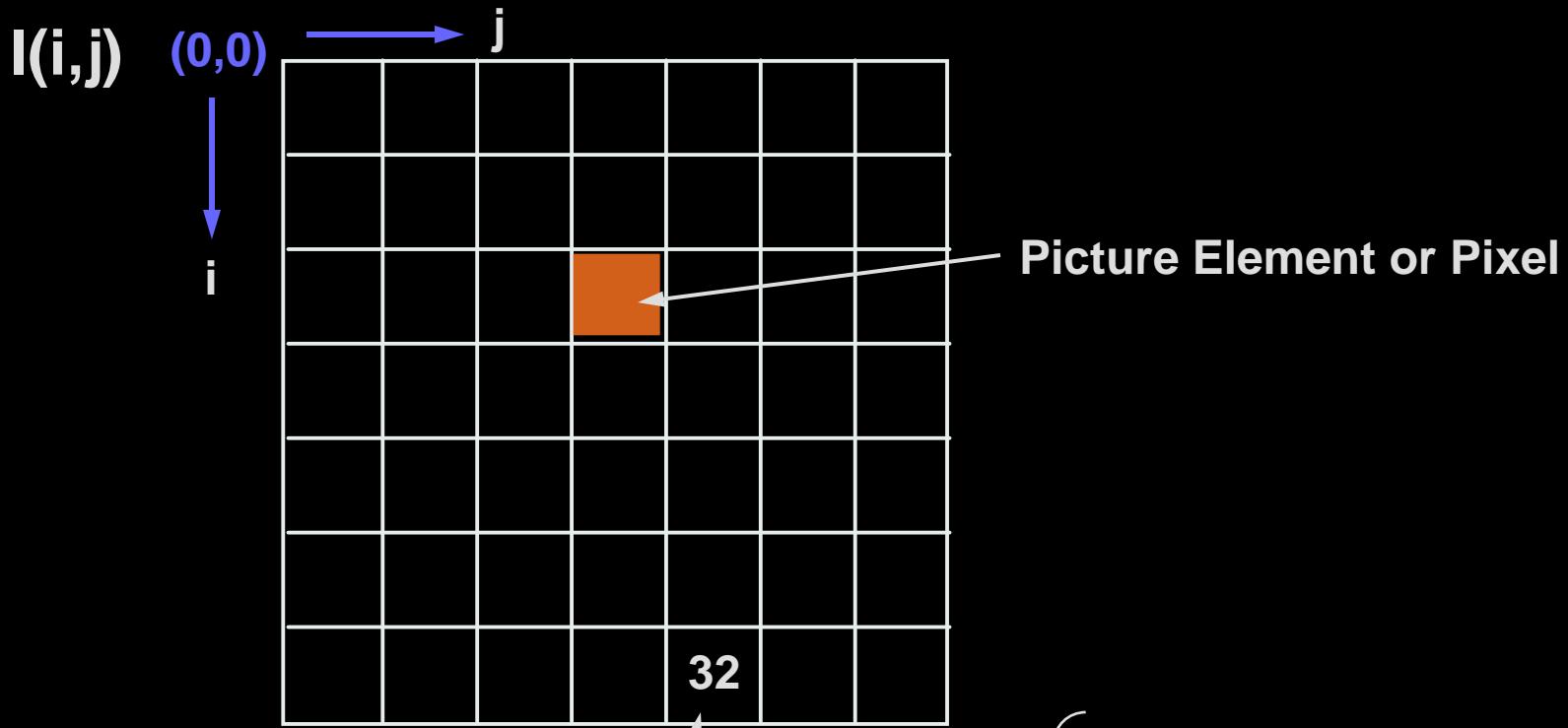

- Neighborhood
- Connectedness
- Distance Metrics

Pixel value $I(l,j) =$

0,1 Binary Image
0 - K-1 Gray Scale Image
Vector: Multispectral Image

- Binary image with multiple 'objects'
- Separate 'objects' must be labeled individually

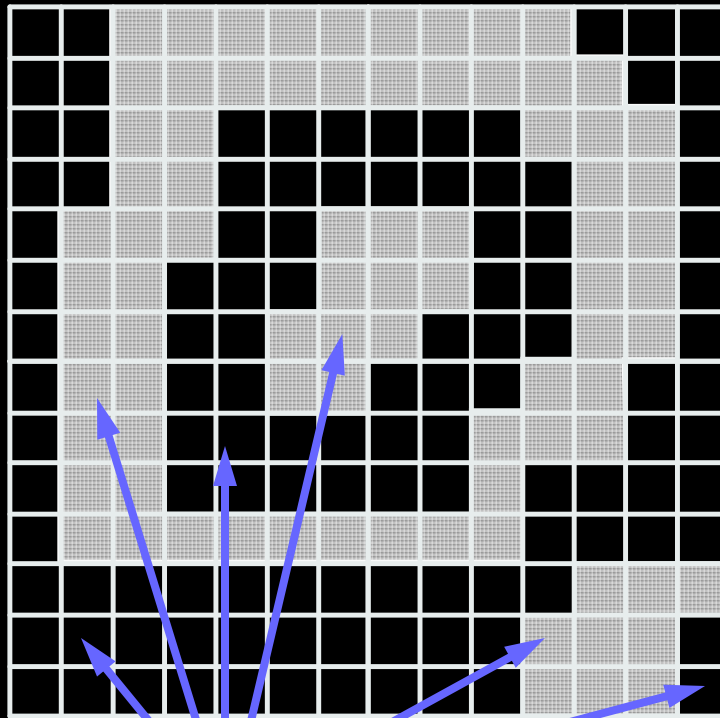

6 Connected Components

- Two points in an image are 'connected' if a path can be found for which the value of the image function is the same all along the path.

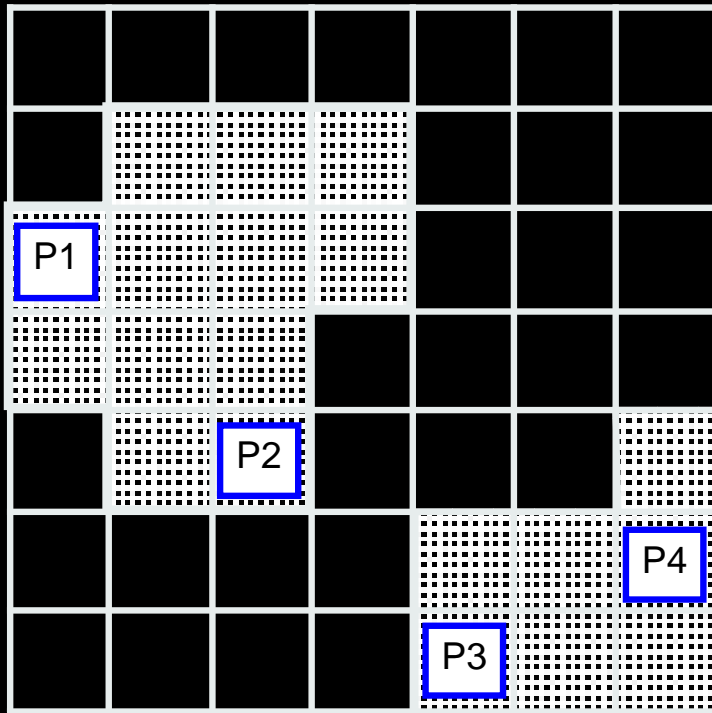

P_1 connected to P_2

P_3 connected to P_4

P_1 not connected to P_3 or P_4

P_2 not connected to P_3 or P_4

P_3 not connected to P_1 or P_2

P_4 not connected to P_1 or P_2

- Pick any pixel in the image and assign it a label
- Assign same label to any neighbor pixel with the same value of the image function
- Continue labeling neighbors until no neighbors can be assigned this label
- Choose another label and another pixel not already labeled and continue
- If no more unlabeled image points, stop.

Who's my neighbor?

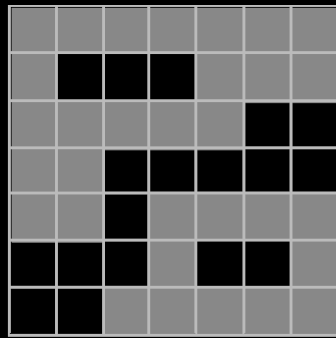

Image

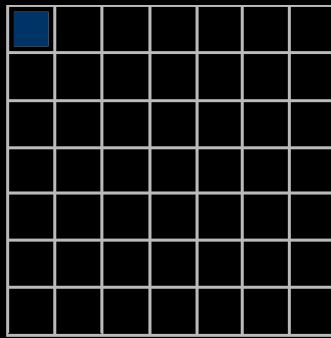

'Label' Image

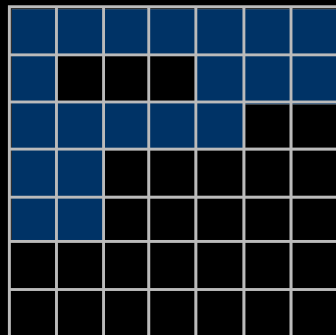
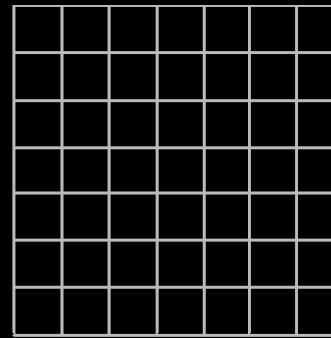

Lab. Im. - 1st Component

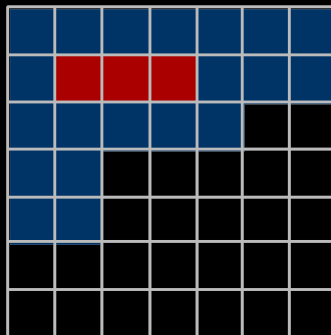

Lab. Im. - 2nd Component

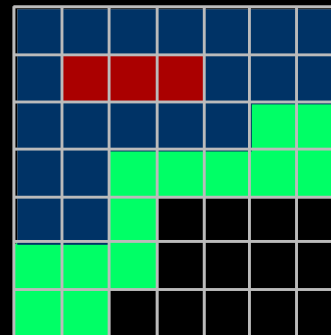

Lab. Im. - 3rd Component

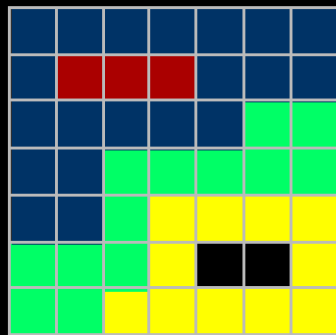

Lab. Im. - 4th Component

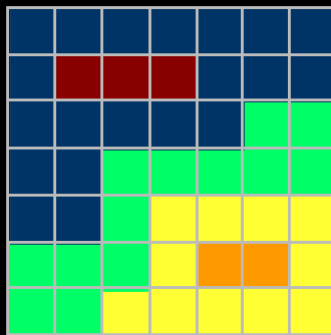

Final Labeling

- Consider the definition of the term 'neighbor'
- Two common definitions:

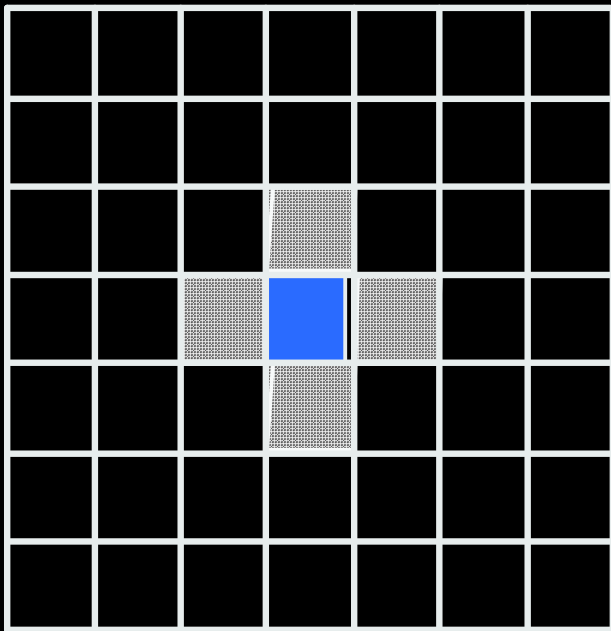

Four Neighbor

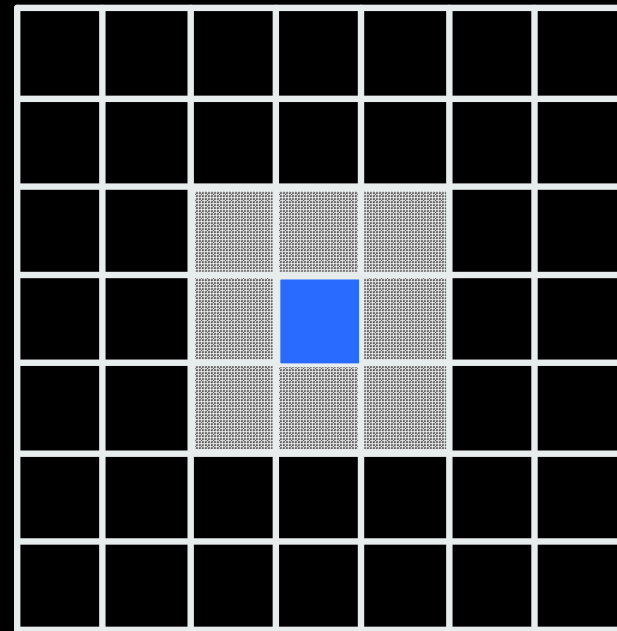

Eight Neighbor

- Consider what happens with a closed curve.
- One would expect a closed curve to partition the plane into two connected regions.

Alternate Neighborhood Definitions

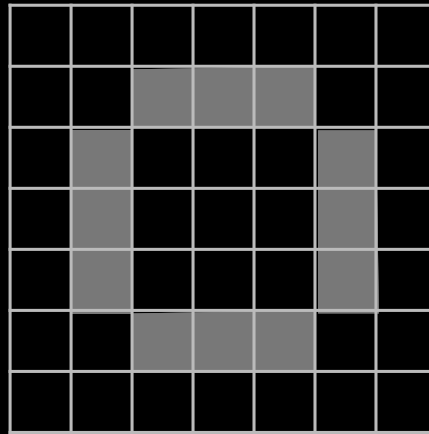

4-neighbor
connectedness

8-neighbor
connectedness

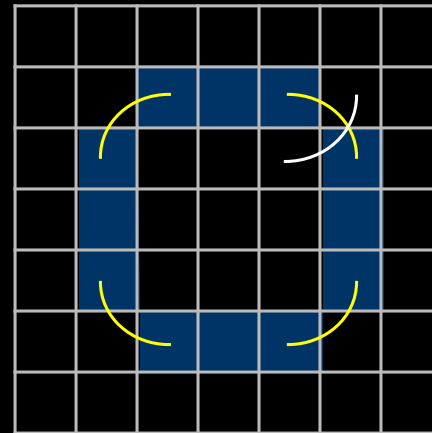
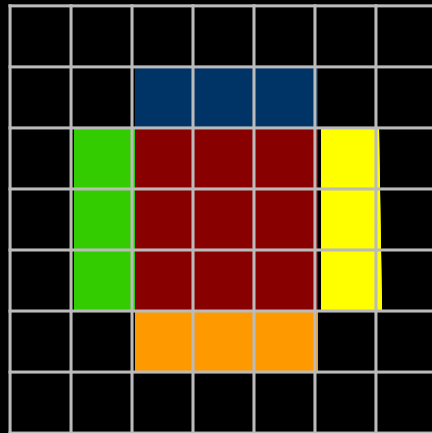

Neither neighborhood definition satisfactory!

- Use 4-neighborhood for object and 8-neighborhood for background
 - requires a-priori knowledge about which pixels are object and which are background
- Use a six-connected neighborhood:

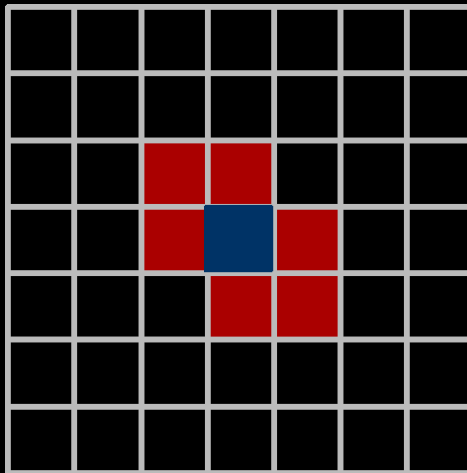

- Alternate distance metrics for digital images

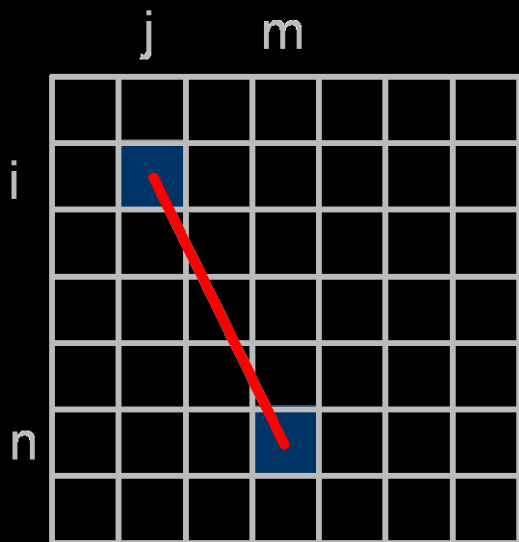

Euclidean Distance

$$= \sqrt{(i-n)^2 + (j-m)^2}$$

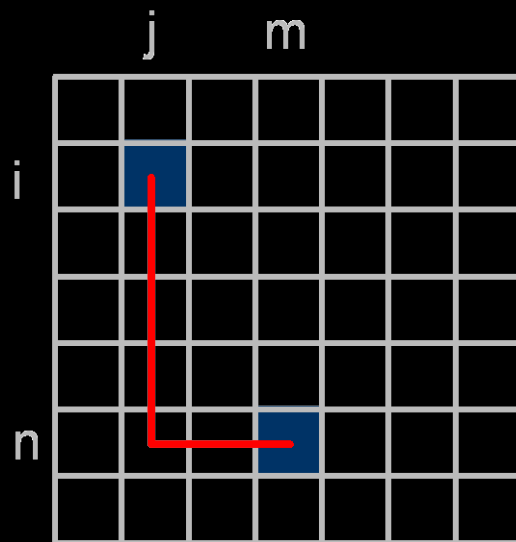

City Block Distance

$$= |i-n| + |j-m|$$

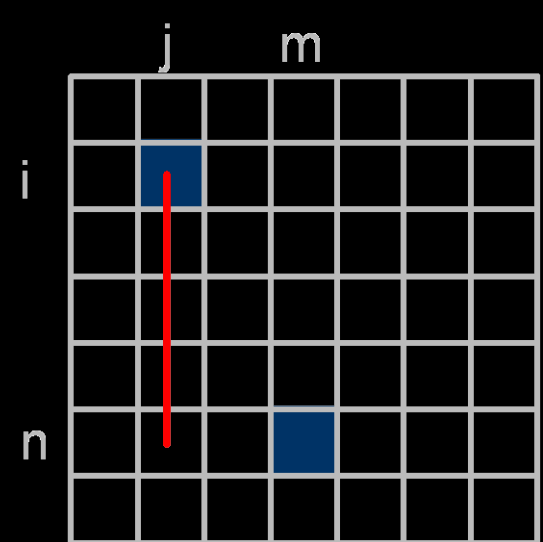

Chessboard Distance

$$= \max[|i-n|, |j-m|]$$

Next: Feature Extraction

- Homework #1 online, Due Sep 13 before class